

INTEWA

CE



INTEWA

Two-part plastic underground tank ET-2000-2

Assembly and operating instructions

WATER, WE'RE IN OUR ELEMENT

Contents

1.	Introduction and scope of application	2
2.	Safety instructions	2
2.1	General notes on the underground tank	2
2.2	Legal situation / regulatory conditions	3
2.3	Responsibility	3
3.	Scope of delivery	3
4.	Technical data	4
4.1	EU - Konformitätserklärung	5
5.	Assembly and sealing of the tank section	6
5.1	Test assembly	6
5.2	Assembly	6
6.	Placement and installation instructions	16
6.1	Site selection and conditions	16
6.1.1	Soil conditions	16
6.1.2	Installation in groundwater or layered water or cohesive soils	16
6.1.3	Construction pit	17
6.1.4	Distance from buildings	19
6.1.5	Slope	19
6.1.6	Pedestrian and traffic loads	19
6.1.7	Backfilling material	20
6.2	Execution of the ground installation	20
7.	Applications	21
7.1	Garden storage tank	21
7.2	Rainwater harvesting home application	23
7.3	Infiltration system	24
8.	Accessories	26
9.	Maintenance and cleaning	26
10.	Warranty / Guarantee	27
11.	Contact	27

1. Introduction and scope of application

Please read these instructions carefully and completely before installing and commissioning the tanks. It is essential to observe the points described. For any additional items purchased, you may find separate installation instructions inside the product packaging (depending on the product).

At least two persons are required for the assembly of the tank as well as for the ground installation!

2. Safety instructions

2.1 General notes on the underground tank



The manhole is provided with cover (not walkable) or with walkable/car passable covers. As a child safety, these must be screwed.



The underground tanks are designed only for underground installation. Above-ground using is not permitted.

The adhesive should be left to dry for at least 24 hours before installation. Do not leave the tank in the direct sunlight! Cover if necessary



It is important to check that the tank is in good condition when it is delivered. Any transport damage must be reported to the courier in an official written form upon receipt of the goods.



Avoid impact loads during transport and installation.



Compliance with the information in these instructions is part of the warranty. All warranty claims will be void if the instructions are not followed.

2.2 Legal situation / regulatory conditions

The construction and operation of rainwater harvesting systems is usually not subject to approval, there is only a notification requirement for domestic use (toilet flushing). Nevertheless, inquire at your responsible authority (building authority, water supplier) for details; local funding opportunities are also advertised in some municipalities.

When manufacturing and installing rainwater harvesting systems (for domestic use), relevant regulations such as DIN 1989; DIN 1986; DIN 18196; ENV 1046; DIN 4124; ATV-DVWK A127 must be followed.

According to DIN EN 16941-1 (On-site systems for non-potable water - Part 1: Systems for the use of rainwater), storage tanks with access for persons must consider the dimensions according to EN 476. If no personal access is provided, the opening must be at least 400 mm. For domestic systems according to DIN EN 16941-1, we therefore recommend using the 400 mm connection opening. For simple garden systems not according to DIN EN 16941-1, the DN300 connection opening is sufficient. Any necessary maintenance can be carried out without operator access by using the suction system.

2.3 Responsibility

The manufacturer is not responsible for damage caused by:

- improper placement of the tank
- installation and sealing mistakes
- ground water, seepage water and backwater
- misuse



These instructions cannot cover all the specifics and details of installing rainwater harvesting systems.

We reserve the right to a tolerance of +/- 4 % for all dimensions and content specifications contained in our catalogues, installation instructions and other documentation. Errors and changes to individual products are reserved within the scope of further technical development.

3. Scope of delivery

Two-part plastic underground tank ET-2000-2	Description	Quantity
	Bottom shell	1 pce.
	Top shell	1 pce.
	Screws, M8 x 50	70 pcs.
	Nuts M8	70 pcs.
	Cover Ø400 mm	1 pce.
	Cover Ø315 mm	1 pce.
	Cover Ø200 mm	1 pce.

Please note that different accessories are required depending on the application. (see chapter Accessories).

4. Technical data

Gross volume:	2000 L
Width:	1208 mm
Length:	2350 mm
Height tank shoulder:	1150 mm
Tank openings:	DN400/Ø400mm DN300/Ø315mm DN200/Ø200mm
Connection surfaces:	12 x DN100
max. soil cover walkable:	1,6 m
max. soil cover car passable:	1,4 m
Structural behaviour:	Test report No. PIA2022-ST-PIT-2204-1026
Declaration of conformity:	CE
Material:	PP
Weight:	80 kg

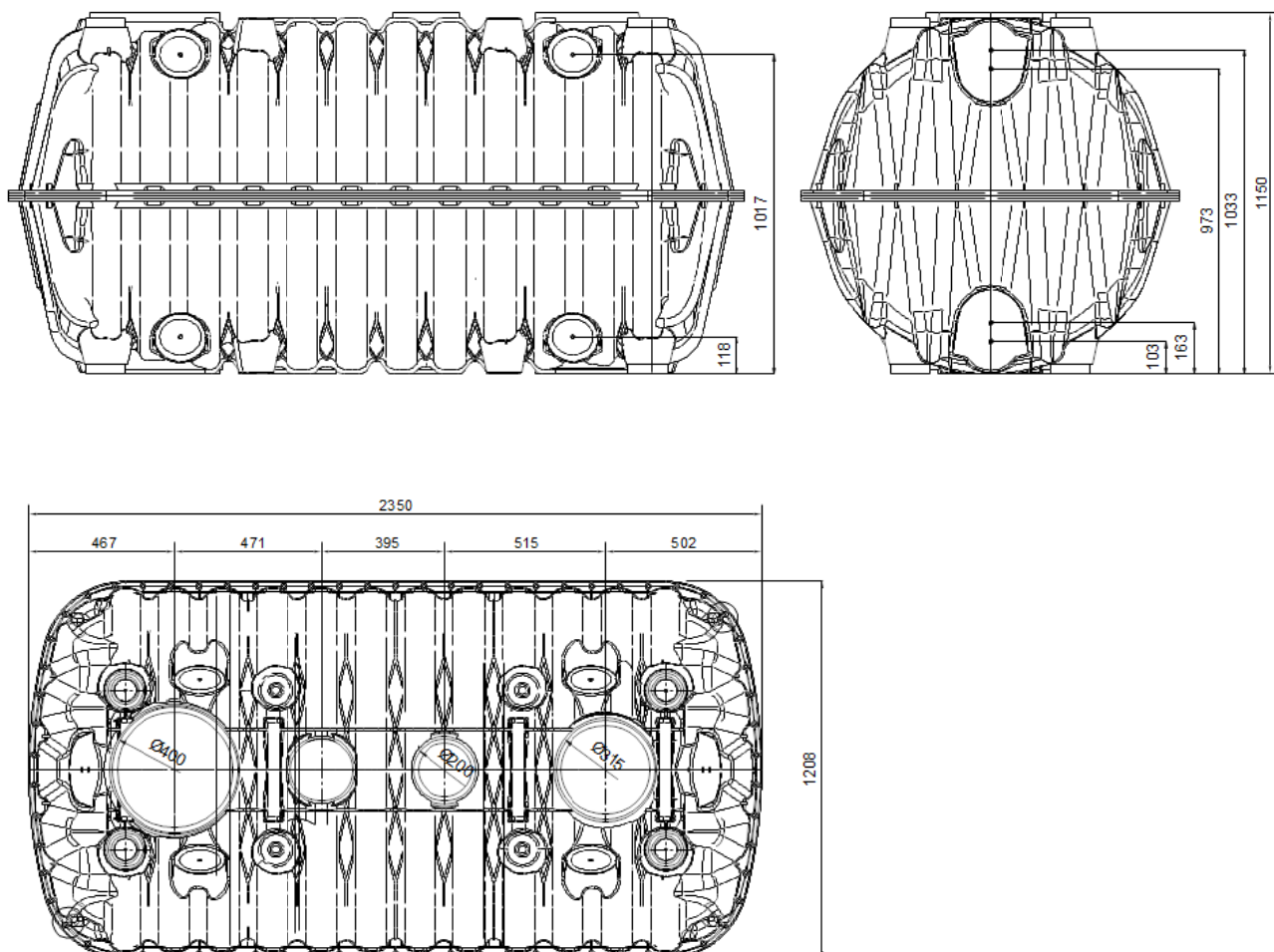

Figure 1: Technical data

4.1 EU – Declaration of conformity

1 **EU Konformitätserklärung**
EU- Declaration of Conformity



2 **Diese EU-Konformitätserklärung wurde in alleiniger Verantwortung von INTEWA GMBH ausgestellt.**
This declaration of conformity is issued under the sole responsibility of INTEWA GmbH.

3 **Dokument-Nr.:** **04/01/2024**
Document-No.:

4 **Hersteller:** INTEWA GmbH
Manufacturer:

5 **Anschrift:** Auf der Hüls 182
Address: D – 52068 Aachen

6 **Produktbezeichnung:** **7** Kunststoffspeicher
Product designation: Plastic storage tank

8 **Typenbezeichnung:** ET-2000-2
Type:

9 **Angewandte harmonisierte Europäische Prüfnormen:**
Applied harmonised European Standard:

- EN 12566-1:2000 +A1:2003
- EN12566-1 Annex D6
- EN 12566-3 Annex C

Test report No. PIA2022-ST-PIT-2204-1026

10 **Ort, Datum:** **Aachen, 04.01.2024**
Place, Date:

11 **Rechtsverbindliche Unterschrift:**
Legal signature:



12 **Geschäftsführer Oliver Ringelstein**
Manager

|

5. Assembly and sealing of the tank section

Before installation in the excavation pit, the tank must be sealed outside the tank excavation pit on a level surface. Working temperatures between 5 ° - 25 °C must be maintained. Do not work in the direct sun! The adhesive needs to dry for at least **24 hours** before the tank can be installed and filled with water.

Hint:

Bonding/sealing of the tank halves does not apply for the infiltration application. The sealing material kit is therefore a separate accessory (see chapter Accessory items).

2 persons are required for assembly.

The following tools are required: Cutter, cartridge press, spiritus, cordless screwdriver with nut 14mm, open-end wrench 14mm

5.1 Test assembly

The tank should be assembled on a trial basis up to assembly step 10 before applying the primer and adhesive. In this way, you get used to the handling for placing the tank shells on top of each other.

5.2 Assembly

Safety instructions adhesive and primer:



- Wear safety glasses during drilling for the coupling.
- Wear protective gloves and appropriate work clothing during handling and sealing.
- Ensure sufficient ventilation!
- Keep adhesive and primer away from children!

- 1.) Set up the tank halves with the contact surface on top and check that they are in good condition!



2.) Thin residual ridges may still be present due to production. These must be removed with a cutter.

Be aware of the rules for safe cutting with a cutter!



before



after

3.) Coupling of tanks:

Use the drill bit to drill the core hole for the rubber bushing. The coupling may only be made on the front side. The distance between the tanks must be at least 400mm so that compaction between the tanks is still possible.

Make sure that the rubber seal is evenly positioned in the drilled hole. Then grease KG DN100 coupling pipe and push it in for about 20 cm.

Notice:

- Wear safety glasses
- The DN100 KG pipe must be purchased locally.
- Drill bit and rubber seal see INTEWA accessories

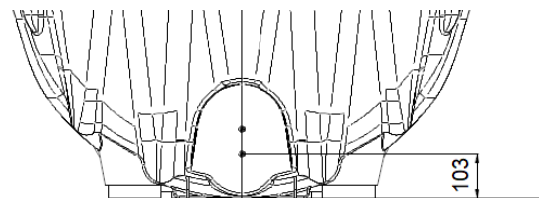

The coupling may only be made on the front side. There are two variants for this:

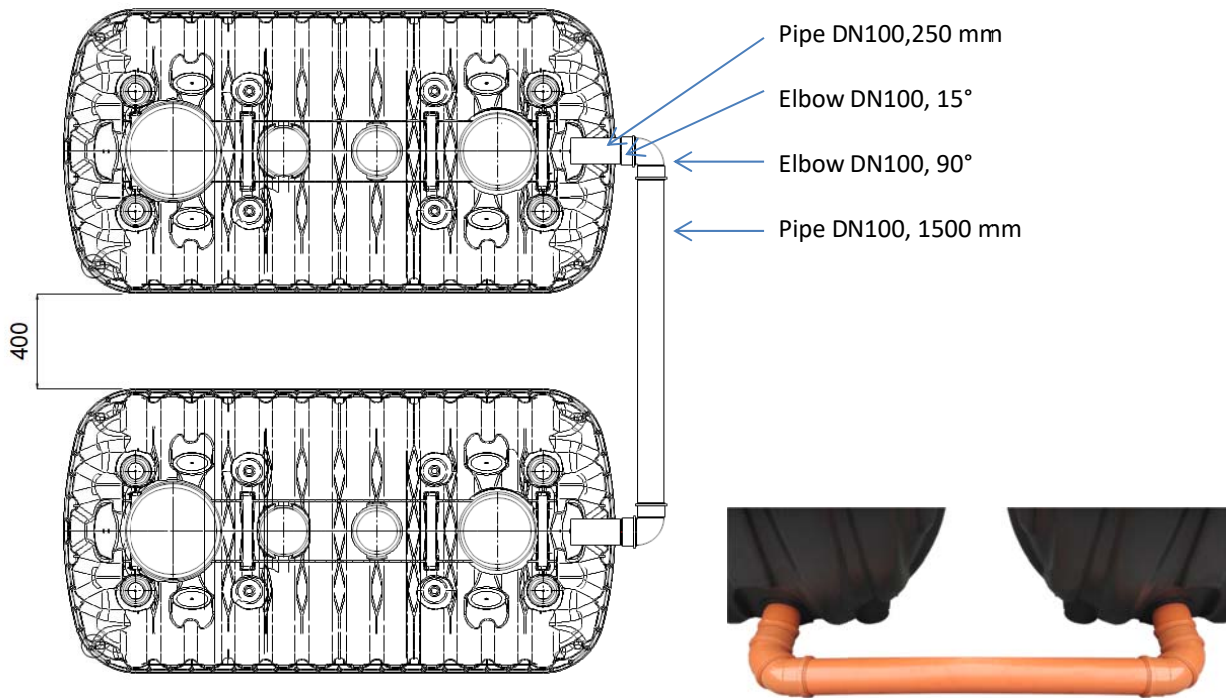

Variant 1: Parallel arrangement (drawing: view from bottom) with 15° elbow and 90° elbow

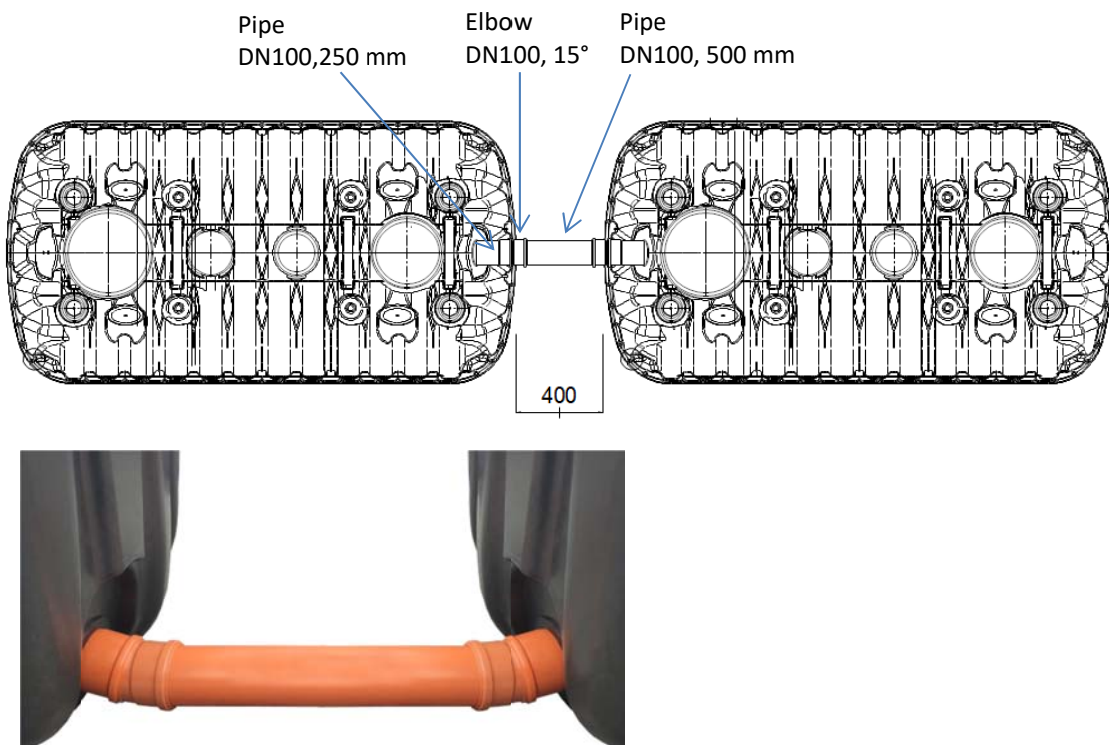

Variant 2: Row arrangement with 15° elbow

4.) Clean and remove grease from the contact surfaces of the half shells with ethyl alcohol and rub dry..

Note:

Use commercially available ethyl alcohol (not included in the scope of delivery).



5.) Then apply the enclosed primer sparingly to the entire contact surface of both half shells using the enclosed foam brush. (Surface only needs to be lightly wetted once.)



6.) For assembly preparation, now insert a bolt from below on each corner of the lower tank shell (hole position as shown in the figure*) and screw it with a nut. (This allows for guidance when draining the upper tank half).

*sixth hole from center line

Hint:

Do not tighten nuts, screws should be movable.

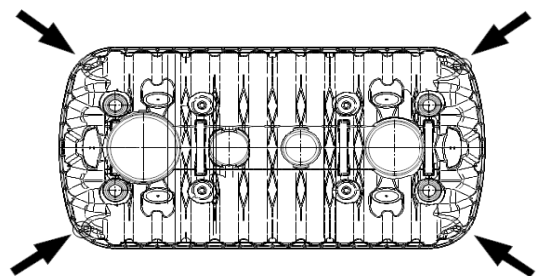

7.) For later removing the nuts, the cable straps (included in the sealing material kit) are used.



8.) Take the enclosed cartridge and shorten the nozzle tip by approx. 20 mm. (This creates a bead of adhesive approx. 5 mm wide).



9.) Place an even adhesive bead of \varnothing 5 mm on the underside of the tank. Connect the beginning and the end of the adhesive bead so that no joint can occur.

Attention:

Approx. 3/4 cartridge is required for total sealing. The rest can be used for sealing the covers/chamber.

Processing time of the adhesive: approx. 25 min. Half shells must be joined together within this time and then screwed together.



10.) The upper half shell is placed on the lower half shell with 2 persons. The placing is assisted by the "guide screws". The upper half shell is now still lying on the nuts.



11.) Before finally lowering the tank halves onto the gluing surface, 10 screws are inserted through both tank halves from above without screwing. Four screws per head side (each to the left and right of the guide screw) and centrally on the long sides.

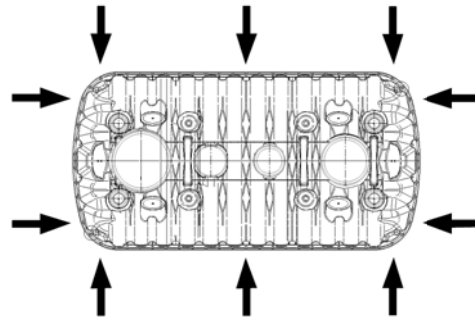

12.) Now the nuts can be removed. To do this, unscrew the screws and pull out the nut with the cable straps.



13.) The tank can then be screwed together. Use a 14 mm open-end wrench and a cordless screwdriver for this purpose. Set the cordless screwdriver to position 5 - 10 (torque should be approx. max. 5 Nm).



14.) The screws must be tightened again evenly by hand.
Wipe off excess adhesive afterwards.



15.) Let the adhesive harden for at least 24 hours before the tank can be installed and filled with water. Do not leave the tank in direct sunlight.



- 16.) Fix the manhole (optional see PLURAFIT accessories):
Clean the sealing surfaces of the tank and manhole and prime them.
Pull an adhesive bead (\varnothing 5 mm) into the support bead.

Ensure the correct positioning of the inlet and overflow connections.



17.) Sealing of the cover:

Tank orifices that are not in use and covered with soil are sealed with the enclosed cover. They can also be sealed with glue.

When gluing the caps, proceed as in step 16. After the solvent has evaporated, draw a bead of glue (\varnothing 5 mm) in the slot of the covers and press the covers into place.



18.) Child Safety:

All covers, e.g. PLURAFIT caps or the car accessible covers must be screwed evenly around the entire perimeter to the manhole or tank by the customer using four woodscrews After installation, the secure mounting must be rechecked!

The telescopic manhole cover has an integrated child safety lock.



Fastening cover



Fastening PLURAFIT cap



Fastening car accessible cover

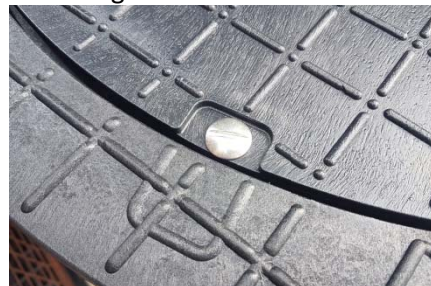

Telescopic manhole cover with
Screwing on top

6. Placement and installation instructions

6.1 Site selection and conditions

6.1.1 Soil conditions

The subsoil must have sufficient load-bearing capacity and the surrounding soil must be capable of percolating (to determine the soil physical conditions, a soil report should be obtained from the local building authority). The distance of the tank bottom to the groundwater level must be > 1m.

6.1.2 Installation in groundwater or layered water or cohesive soils

Installation of the tanks in areas with permanent or temporary groundwater, layered water or backwater is only possible and permissible if the conditions listed below are met.

The measures required for this (e.g. drainage or dewatering) are to be carried out and checked professionally (if applicable). Any drainage pumps installed for the purpose of dewatering must be checked regularly for proper functioning.

When installing the tank in areas with cohesive soil, it must be ensured, e.g. by using a circular drainage system, that the formation of troughs (water accumulation in the bedding) is avoided.



Installation of the tank in areas with permanent or temporary groundwater, layer or backwater must be avoided. Drainage with a pump pit is required for these conditions.

6.1.3 Construction pit

Sufficient area must be available for the excavation pit so that working space widths and slope angles can be maintained. The minimum and maximum soil cover (H) must be considered depending on the load:

Walkable: Minimum soils cover: 0.22 m
Maximum soil cover: 1.60 m

car passable (car max. 3,5 t) : Minimum soil cover: 0,80 m
Maximum soil cover : 1,40m

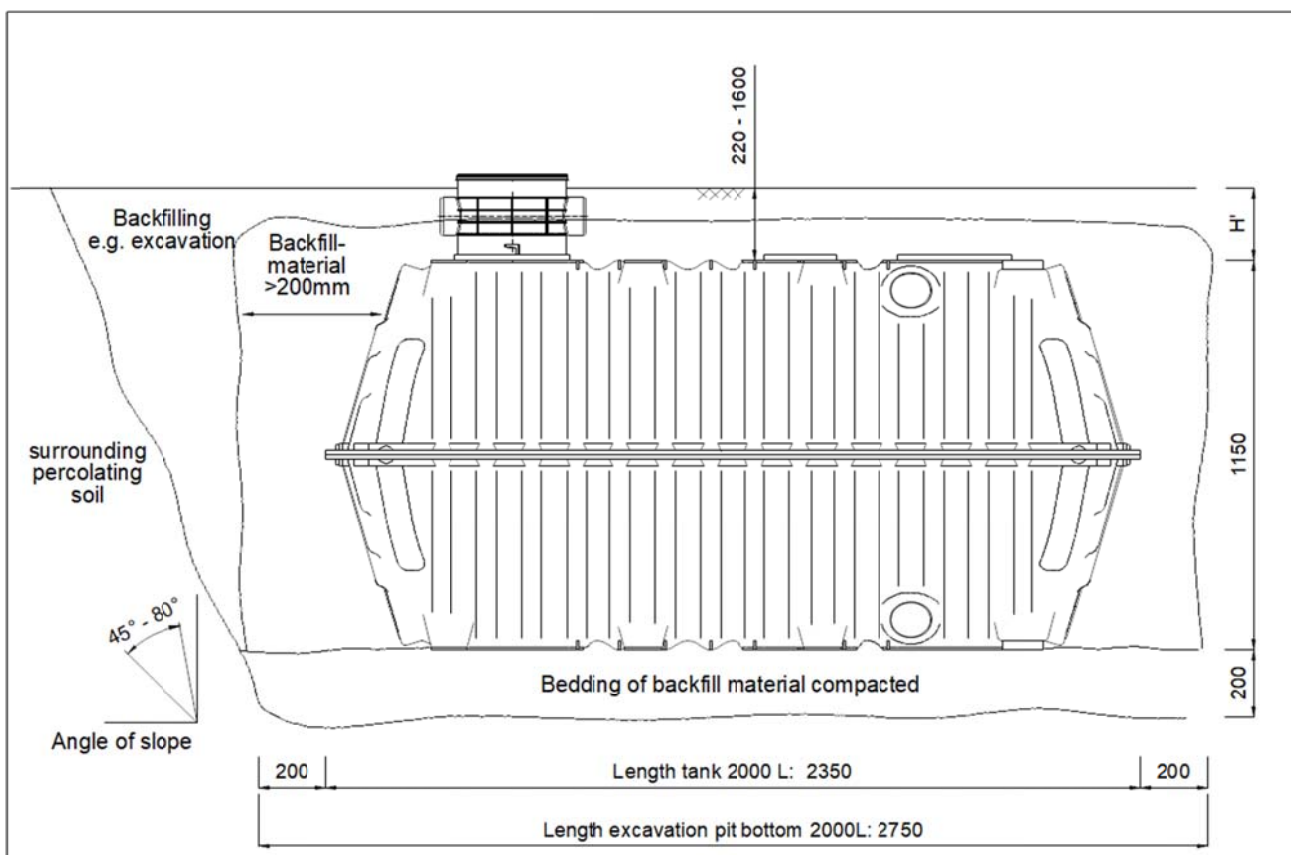

Figure 2: Installation walkable version

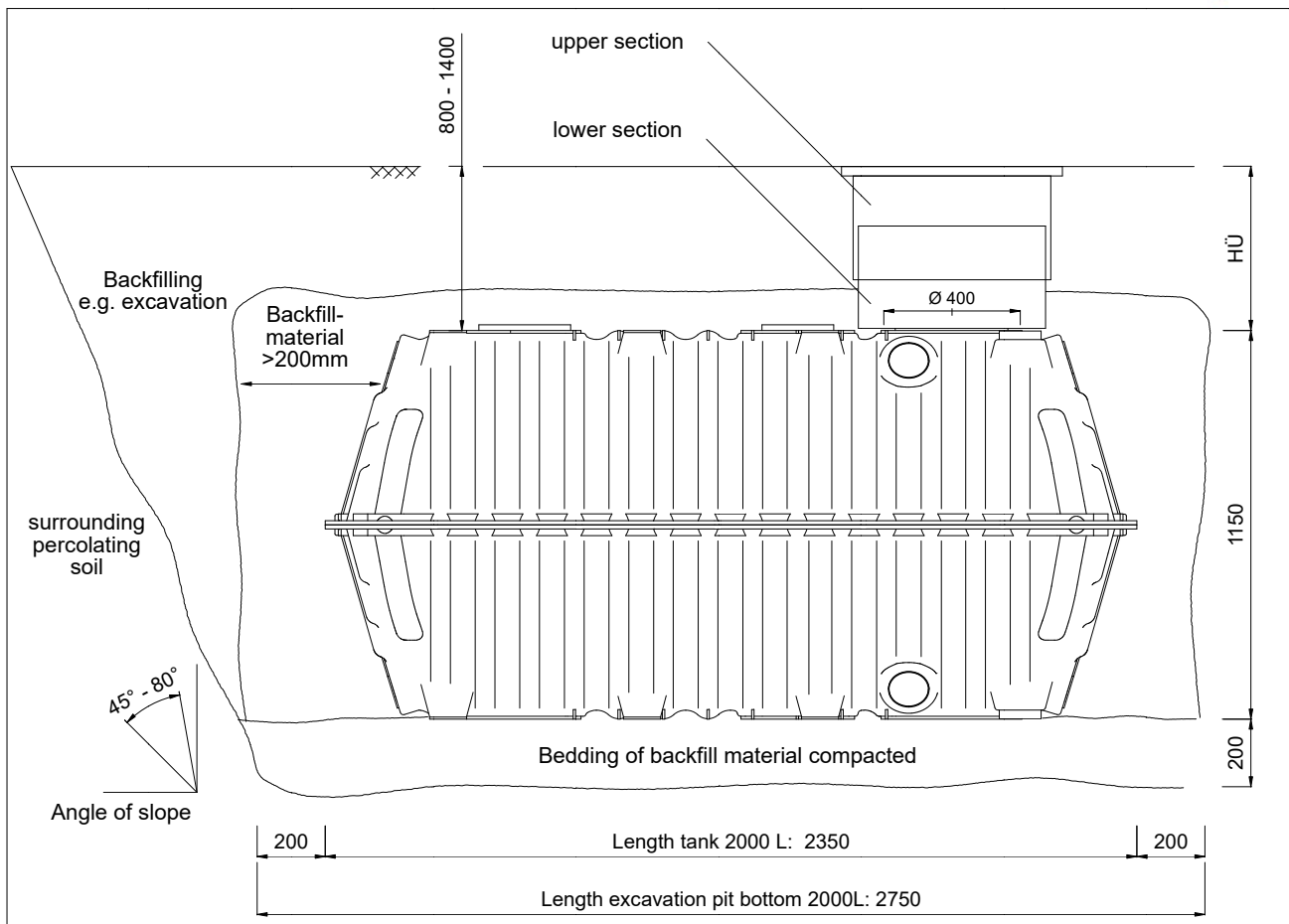

Figure 3: Installation trafficable version with telescopic dome

Note:

Only the lower part of the telescopic shaft rests on the storage tank. The upper section is decoupled and must not rest on the storage tank and must not be mechanically connected (e.g. bolted) to the lower section of the shaft.

6.1.4 Distance from buildings

The tanks shall not be placed over building and cannot bear any loads from buildings or foundations. The distance to buildings must be at least 1.5 m. If the bottom of the excavation is deeper than the top of the foundation, this distance increases to 3-6 m (for more information: DIN 4123) corresponding to a load support angle of 45°.

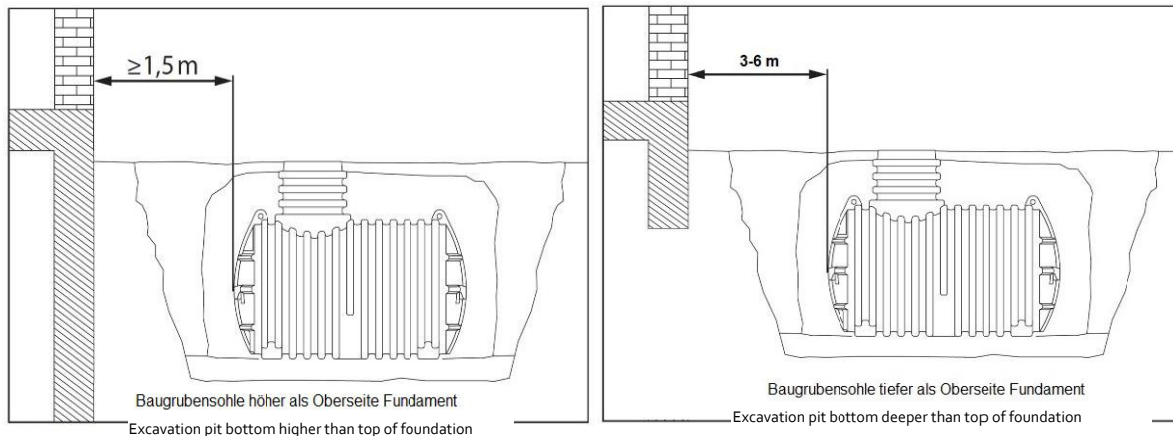

Figure 4: Distance to the building

6.1.5 Slope

In case of a slope, the terrain must be examined for the risk of slipping of the soil and, if necessary, it should be stabilized with a statically calculated retaining wall (DIN 1054, DIN 4084). For further information, please contact your local authority or local construction companies.

6.1.6 Pedestrian and traffic loads

The tank can be covered with the following separately ordered covers for traffic areas of class A according to EN124 (cyclists, pedestrians): PE cover, telescopic segment.

Cover cap:	not walkable
PLUARAFIT cover:	walkable
PLURAFIT cover PF 111 kN:	car accessibility
Telescopic manhole ET-TD-BF:	car accessibility

6.1.7 Backfilling material

The backfill material must be specified as shear resistant, well compactable, permeable to water and air, and frost resistant, and must be compactable and not contain excessively sharp components. These requirements are met, for example, by sand-gravel mixtures or crushed stone with grain sizes of 1/4 to 8/16 mm. (Ask your building materials dealer). The use of excavated soil, especially with a clay content, is not suitable.

6.2 Execution of the ground installation

In preparation for placing the tank in the excavation pit, the bedding of backfill material (200 mm thick) is placed in the pit bottom. The surface must be accurately horizontal.

- The tank and its components must be checked to ensure that they are in good condition.
- The placement of the tank is done in such a way that it is positioned without striking the pit (e.g. with the help of straps or ropes) and carefully placed on the bottom bedding. A strong impact load is to be avoided!
- Before backfilling from the side, the tank must be filled up to half with water.
- Backfilling/compaction in the lower part of the pit (up to half the height of the tank) is done in such a way that the backfilling material is placed in layers of 100 mm in a width of at least 300 mm around the tank in the pit and compacted with a hand tamper 15kg (no machine use!) by one operation per layer. During backfilling and compaction, constantly observe whether deformations or other signs of uneven compaction are visible on the tank.



Machine compaction is not permitted! The filling material must not be filled in with sludge!

- After backfilling/compaction of the lower part of the pit, the inlet pipe and the empty pipe are laid with a gradient (min. 1 %) to the tank as well as the outlet pipe with a gradient (min. 1 %, equal to or greater than at the inlet). The drain line of the tank can be connected to an existing sewer or to a downstream infiltration system. If the drain line is connected to an infiltration system, it must be at least 3 m away from the tank.
- The tank is then filled with water up to the lower edge of the connections. This can also serve as a leak test at the same time (wait 15 min)
- For backfilling/compaction up to about 200 mm below ground level, proceed as described for the lower part of the pit. Please note: Before backfilling/compaction around the connections, these must be checked to ensure that they are free of stress and that they are properly attached!
- Residual backfilling, above the tank shoulder, may be topsoil or excavated material or similar.

7. Applications

7.1 Garden storage tank

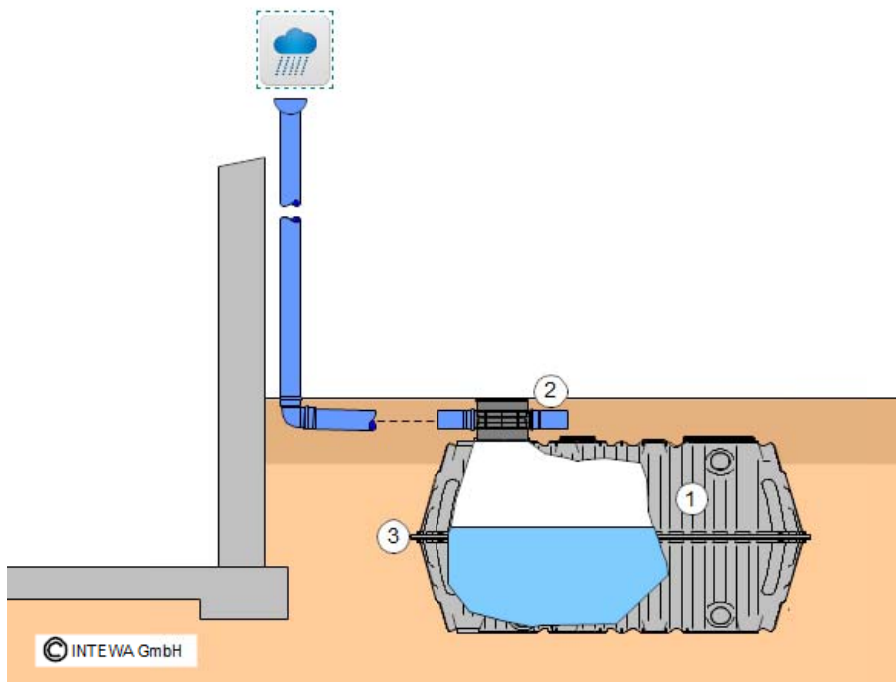

Figure 5: Example system Garden system 2000 liters

- | | | |
|---|-----------------|---|
| 1 | ET-2000-2 | Underground plastic tank, two-shell |
| 2 | PF300-100-Basis | PLURAFIT basic element |
| 3 | ET-2000-SKit | Sealing material set for tank ET-2000-2 |

Note: Different filters can be used in the PLURAFIT basic element (see PLURAFIT accessories).

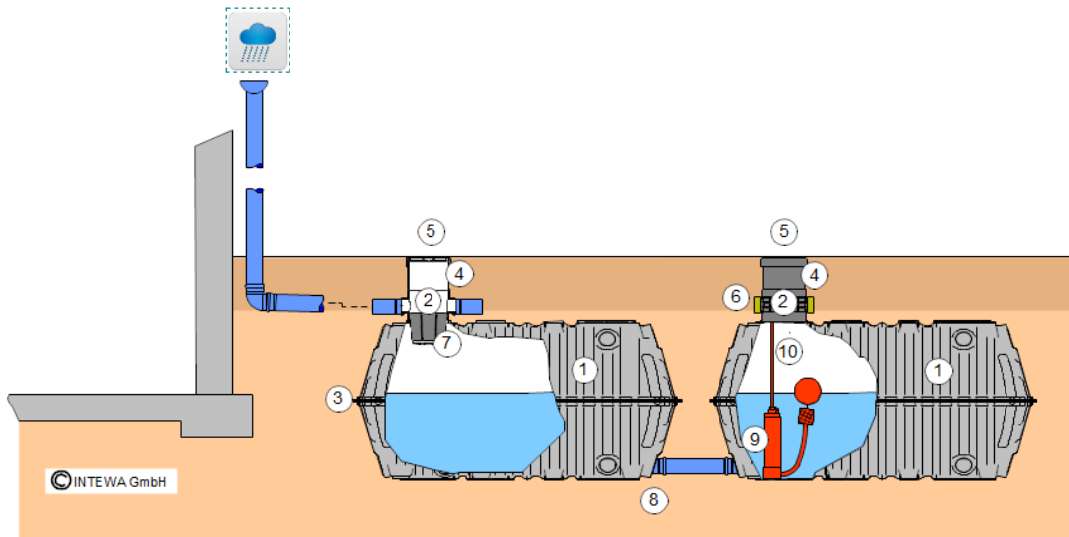

Figure 6: Example system Garden system 4000 liters

1	ET-2000-2	Underground plastic tank, two-shell, 2 pieces
2	PF300-100-Basis	PLURAFIT basic element, 2 pcs.
3	ET-2000-SKit	Sealing material set for tank ET-2000-2, 2 pcs.
4	PF300-S	PLURAFIT chamber extension, 2 pcs.
5	PF300-C	PLURAFIT cap, 2 pcs.
6	PF100-C	PLURAFIT pipe cap, 2 pcs.
7	PF300-FK	PLURAFIT filter basket
8	SEAL110	Rubber seal, 2 pcs.
9	MULTI05-IS-SET	Submersible pump set with Multi-05-IS
10	HORIZON-1 Zoll HSAW-127	HORIZON pressure hose 1 inch, 1,5 m Hole saw Ø127mm for rubber seal SEAL110

Note: The DN100 coupling pipe (KG pipe) must be purchased separately at the local building materials store/building supply store.

7.2 Rainwater harvesting home application

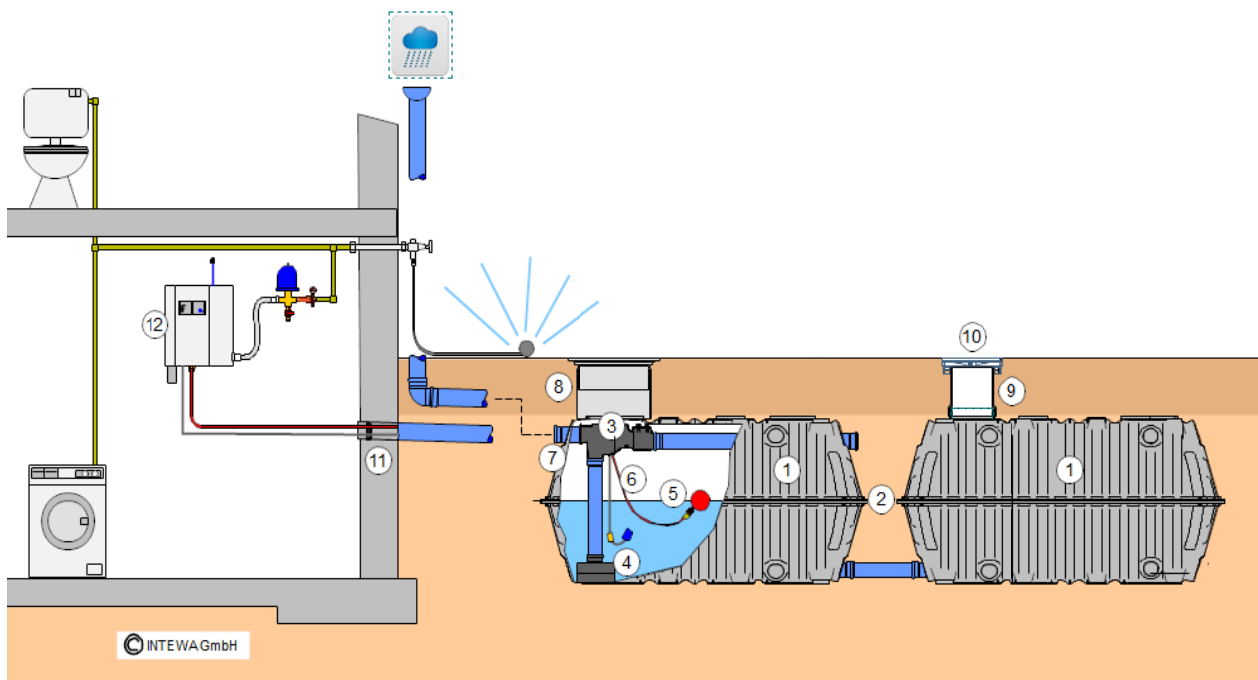

Figure 7: Example system Home application

1	ET-2000-2	Underground plastic tank, two-shell, 2 pcs.
2	ET-2000-SKit	Sealing material set for tank ET-2000-2, 2 pcs.
3	PR100	PURAIN filter DN100
4	PF300-100-Calm	PLURAFIT inlet calming DN100
5	SAUGSAGF-½ Zoll	Suction set with coarse filter 1/2 inch
6	HORIZON-½ Zoll	HORIZON suction hose 1/2 inch, 10 m
7	SEAL110	Rubber seal, 5 pcs.
8	ET-TD-BF	Telescopic dome incl. car accessible cover
9	PF300-S	PLURAFIT chamber extension cap, 2 pcs.
10	PF300-C111	PLURAFIT chamber cover, car driveable
11	MD100	Wall duct DN100
12	RM-Eco10	RAINMASTER Eco 10

7.3 Infiltration system

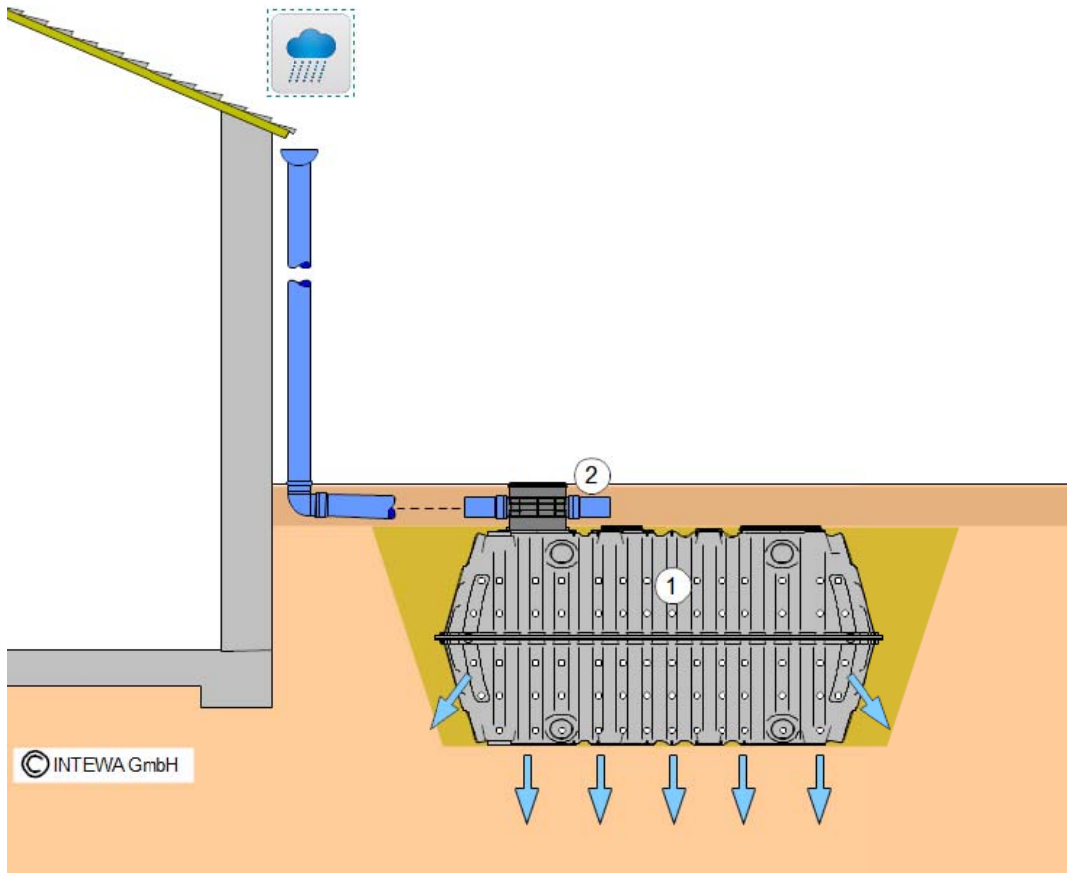

Figure 8: Example system infiltration 2000 liters

- | | | |
|---|----------------------------------|--|
| 1 | ET-2000-2 | Underground plastic tank, two-shell |
| 2 | PF300-100-Basis
ET-2000-GT105 | PLURAFIT basic element
Geotextile fleece 2.5 x 4.0 m for tank ET-2000-2 |

In this application, the tank are only screwed together and not glued. The top and bottom sides are drilled with $\varnothing 20$ mm holes (see drilling plan). For drilling the infiltration holes, we recommend our flat milling drill $\varnothing 20$ mm, FDRILL-20.

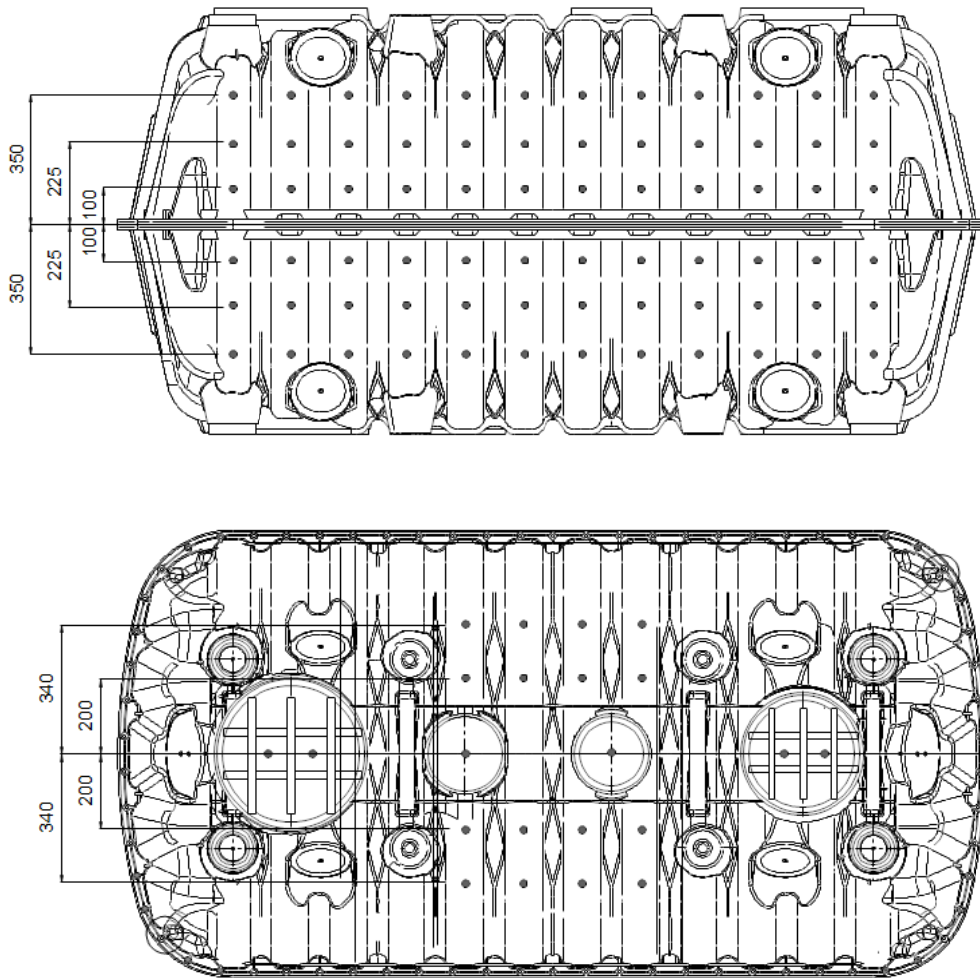





Figure 9: Drilling plan for side and bottom area

8. Accessories

Code Art.-Nr.	Accessories	
ET-2000-SKit 110098	Sealing kit for underground tank ET-2000-2	
ET-2000-GT105 110094	Geo textil for underground tank ET-2000-2, 10m ²	
FDrill-20 900523	Flat drill bit \varnothing 20mm	
HSAW-127 900522	Hole saw for rubber seal SEAL110	
SEAL110 900525	Rubber seal DN100/ \varnothing 110mm, for wall thickness up to 5 mm	

All other accessories such as chambers filter inserts and covers can be found in the INTEWA store.

9. Maintenance and cleaning

Regular inspection and maintenance ensures higher functional safety and service life of your rainwater harvesting tank. The cleaning of the tank and also the filter inserts should be carried out at regular intervals. The frequency of maintenance depends on local conditions and is at the discretion of the operator.

The following applies to the plastic covers: Regularly check the covers for secure / child-proof fastening (screw connection on the side).

10. Warranty / Guarantee

INTEWA GmbH provides a warranty of 24 months from the date of delivery. To proof your date of purchase, please keep your purchase receipt.

Within the warranty period, INTEWA GmbH shall provide warranty at its own discretion either by repairing the defective item at the factory or by supplying a replacement.

The complete INTEWA warranty conditions can be found at:
www.intewa.com

In addition, INTEWA provides a 10-year material warranty.

A condition for the warranty claim shall be the proper installation of the tank, in accordance with the installation instructions supplied with the tank, as well as the compliance with the relevant regulations during planning and installation. There is no warranty claim in case of improper use.

In the event of a defect recognized by INTEWA, we will provide material replacement within the warranty period. Any further services for assembly etc. are excluded. The warranty conditions are without any influence on the legal warranty rights.

11. Contact

For customers in Germany:

For questions, spare parts orders, as well as in service cases, please contact INTEWA GmbH directly with the purchase invoice:

INTEWA GmbH
Auf der Hüls 182
52068 Aachen
Germany

Phone: 0049-241-96605-0
Fax: 0049-241-96605-10
E-mail: info@intewa.de
Internet: www.intewa.com

For customers in other countries:

For questions, spare parts orders, as well as in service cases, please contact your dealer or the responsible INTEWA partner who handles all services in the respective country, quoting the purchase invoice.